



**AHE Home Elevators**

# **Design & Planning Guide**

## Purpose

This guide is intended to assist architects, contractors and elevator professionals to incorporate an AHE home elevator into a residential building design. All AHE home elevators meet the applicable requirements of ASME A17.1 section 5.3 Safety Code for Elevators and Escalators.

While this guide provides all necessary information we highly recommend contacting your local elevator installation company prior to the start of construction. To locate your nearest dealer please visit [WWW.AHEHOMELEVATORS.COM](http://WWW.AHEHOMELEVATORS.COM) or call us at 1-800-530-4040

<b>Specification type</b>	<b>Data</b>
Load Capacity	950 Lb
Rated Speed	40 Fpm
Power supply (circuit supplied by others)	230V single phase 30amp
Lighting Supply (circuit supplied by others)	120 volt 15 amp
Drive system	1:2 roped hydraulic with submersed power unit
Maximum Travel	50 Feet
Control System	Microprocessor based controller with led diagnostics
Levels and openings	Up to 4 stops / up to 3 openings
Pit depth	Minimum 9.00"
Overhead	96" for standard 7'0" cab.
Cab size	Dependant upon shaftway size. Not to exceed 15 Square feet
Standard features	Recessed gate pocket Quit 2 speed valve for soft start and stop Submersed pump and motor Automatic cab lighting Car here lights at all hall stations Auto homing feature Battery lowering Unfinished plywood flooring Hardwood veneer cab Accordion Gates
Safety features	Type A instantaneous safetys Manually reset slack rope switch Pipe rupture valve Low pressure switch Positively open gate safety switch Uninterruptible battery backup system for lowering, lighting and door lock operation. Upper an lower limits Emergency stop and Alarm Pit and car top stop switches

# TYPICAL HOISTWAY LAYOUTS

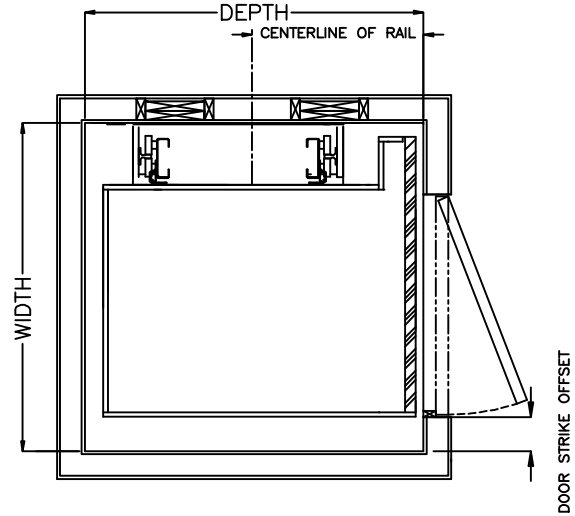
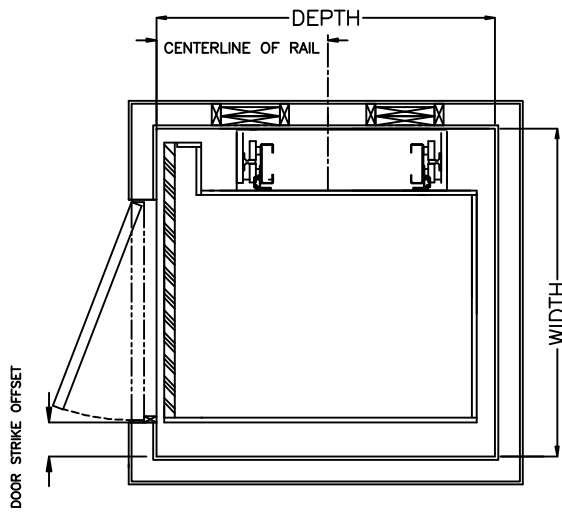

CAR SIZE	WIDTH	DEPTH	CENTER OF RAIL	DOOR STRIKE OFFSET
36" x 48"	54"	54.5"	27.5"	5.25"
42" x 48"	59"	54.5"	27.5"	5.25"
36" x 60"	54"	66.5"	33"	5.25"
40" x 54"	57"	60.5"	30"	5.25"

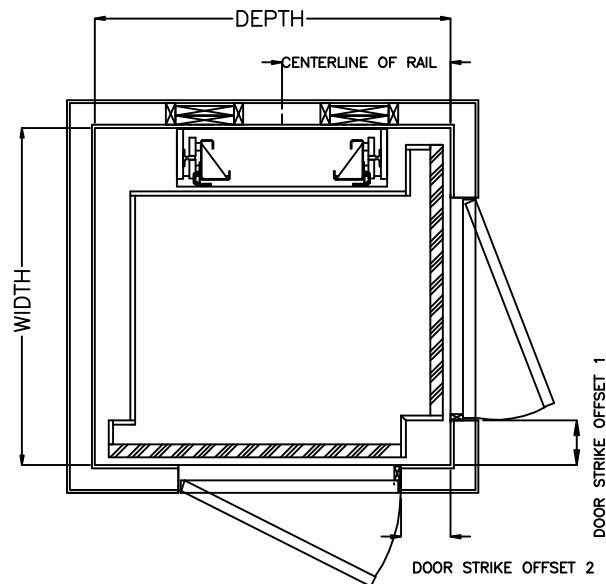
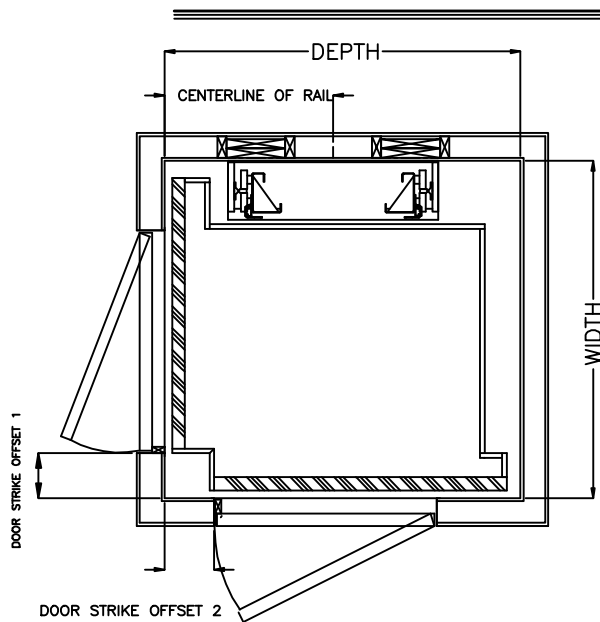

CAR SIZE	WIDTH	DEPTH	CENTER OF RAIL	DOOR STRIKE OFFSET 1	DOOR STRIKE OFFSET 2
40" x 48"	54.75"	57.5"	27.5"	7.25"	8.00"
42" x 48"	56.75"	57.5"	27.5"	7.25"	8.00"
40" x 54"	54.75"	63.5"	30"	7.25"	8.00"

# TYPICAL HOISTWAY LAYOUTS

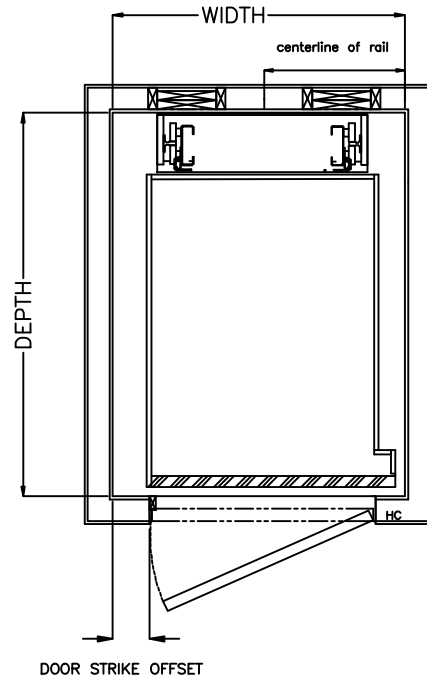
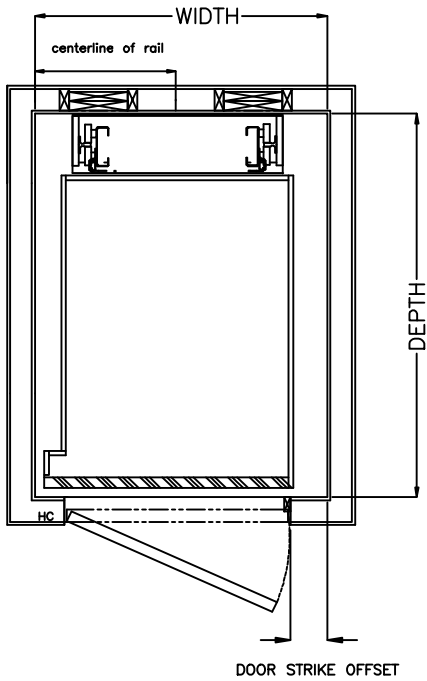

CAR SIZE	WIDTH	DEPTH	CENTER OF RAIL	DOOR STRIKE OFFSET
36" x 48"	47.5"	62.5"	23.5"	5.25"
45" x 48"	55.5"	62.5"	27.5"	5.25"

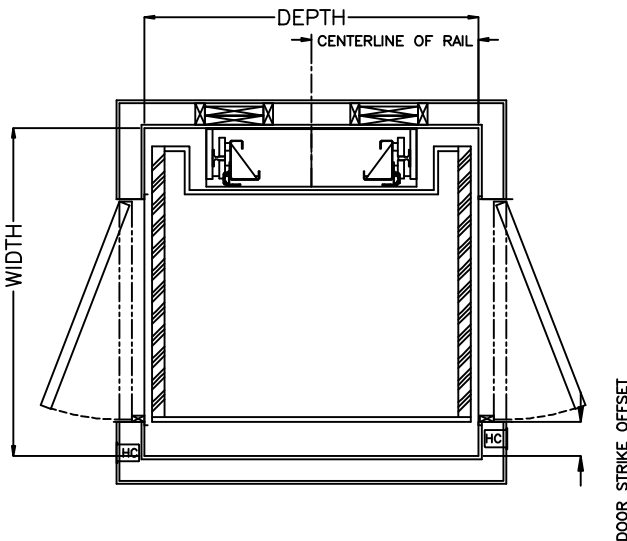

All Dimensions Are finished from inside of drywall and are calculated using a standard car wall thickness of  $\frac{3}{4}$ " please contact your local dealer for custom car sizes and layouts.

Changing of door swings may affect required shaftway dimensions

CAR SIZE	WIDTH	DEPTH	CENTER OF RAIL	DOOR STRIKE OFFSET
36" x 48"	54"	54.5"	27.5"	5.25"
42" x 48"	59"	54.5"	27.5"	5.25"
36" x 60"	54"	66.5"	33"	5.25"
40" x 54"	57"	60.5"	30"	5.25"

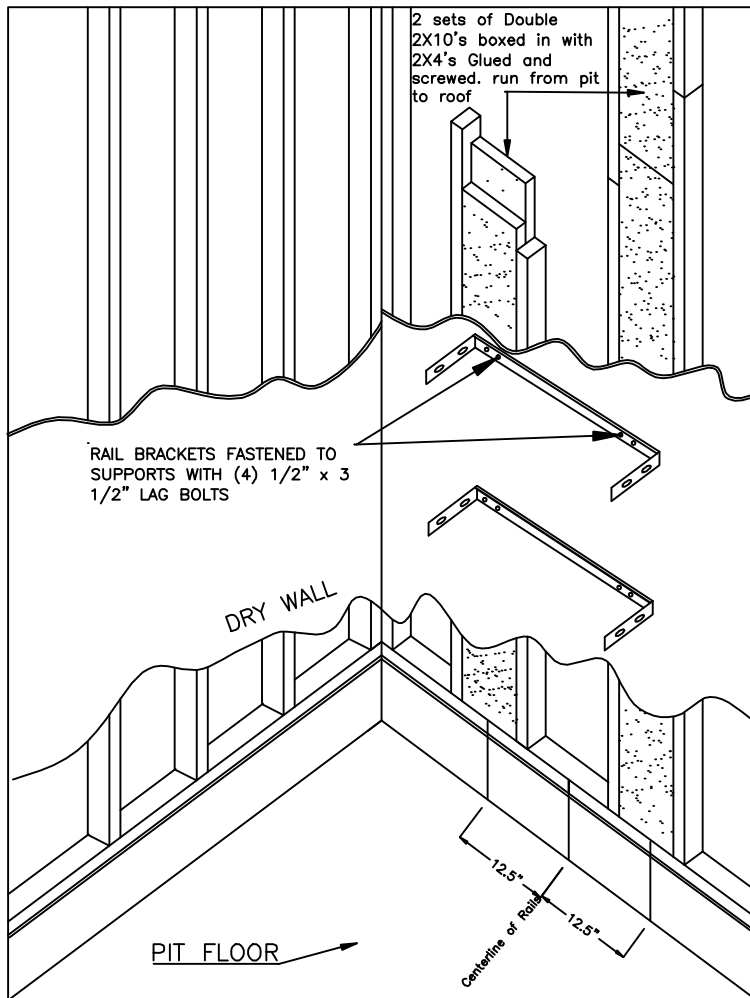

TYPICAL RAIL BACKING DETAIL

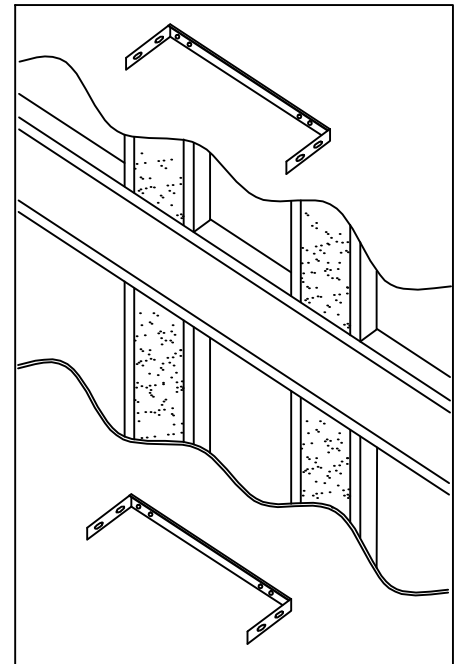

DETAIL AT INTERMEDIATE FLOORS

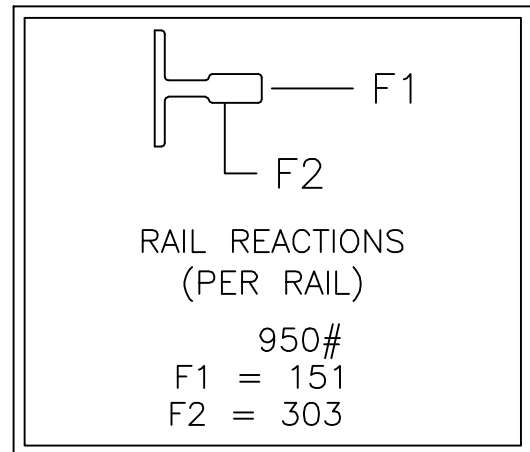

GENERAL CONTRACTOR TO PROVIDE

Sufficient wall supports adequate to hold the rail forces shown above. All rail backings as shown above shall be screwed and glued and fastened to floor joists at intermediate floors with vertical intervals not to exceed 10' without fastening. All joints shall be staggered

# TYPICAL HOISTWAY CONSTRUCTION

(2) 2x10'S FASTENED BETWEEN (2) 2x4'S  
BEHIND DRYWALL AND RUN VERTICALLY  
THE ENTIRE LENGTH OF THE HOISTWAY

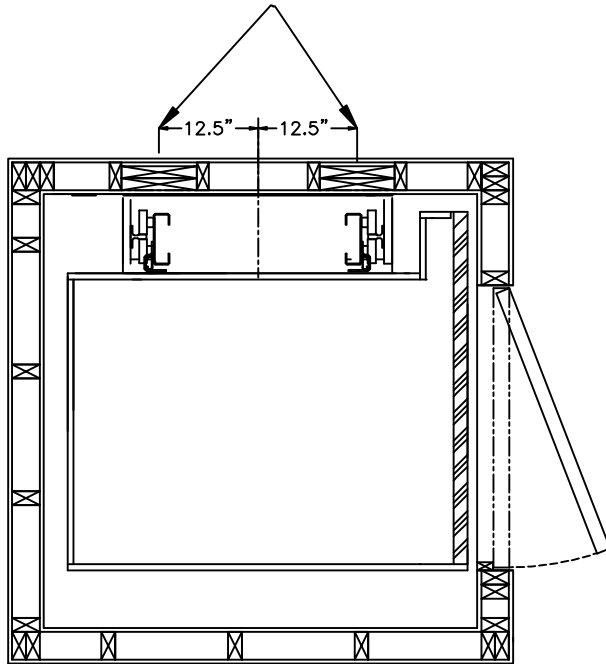

THE ELEVATOR HOISTWAY SHALL BE CONSTRUCTED IN ACCORDANCE WITH ANSI A17.1 AND ALL LOCAL CODES. NO ITEMS NOT DIRECTLY INVOLVED WITH THE FUNCTION OF THE ELEVATOR ARE ALLOWED IN HOISTWAY.

HOISTWAY FRAMEWORK MUST BE PLUMB AND SQUARE WITHIN 1/2" OVER THE ENTIRE RISE. HOISTWAY DOORS TO BE INSTALLED PLUMB ONE ABOVE THE OTHER IN ACCORDANCE WITH A17.1 RULE 5.3.7.1.2 ALL WALLS AND SIDE MEMBERS MUST EXTEND FROM SILL TO BEAM.

ADEQUATE RAIL BRACKET SUPPORT MUST BE PROVIDED AS INDICATED FOLLOWING PAGE DRAWINGS FASTENINGS NOT TO EXCEED VERTICAL INTERVALS SHOWN.

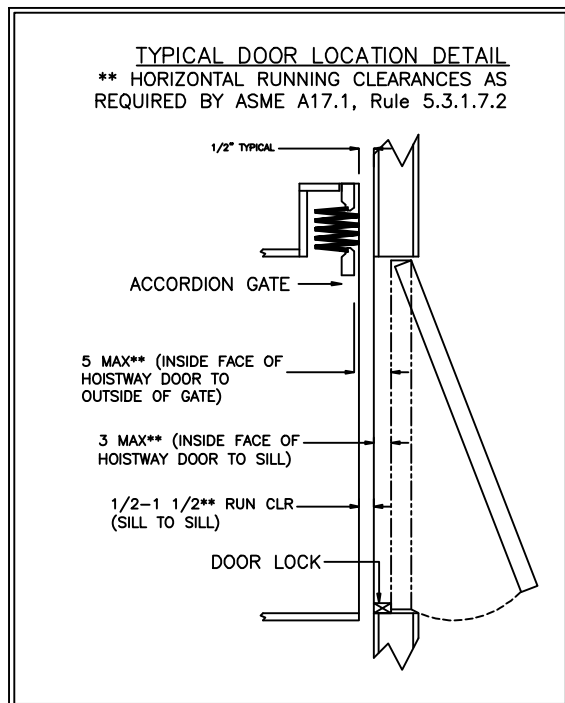

3" X 5"  
RULE

ASME A17.1, Rule 5.3.1.7.2 CLEARANCE BETWEEN HOISTWAY DOORS OR GATES AND LANDING SILLS AND CAR DOORS OR GATES

The Clearance hoisway doors or gates and the hoisway edge of the landing sill shall not exceed 75mm (3 in.) The distance between the hoisway face of the landing door or gate and the car door or gate shall not exceed 125mm (5 in.)

# PIT AND OVERHEAD DETAILS

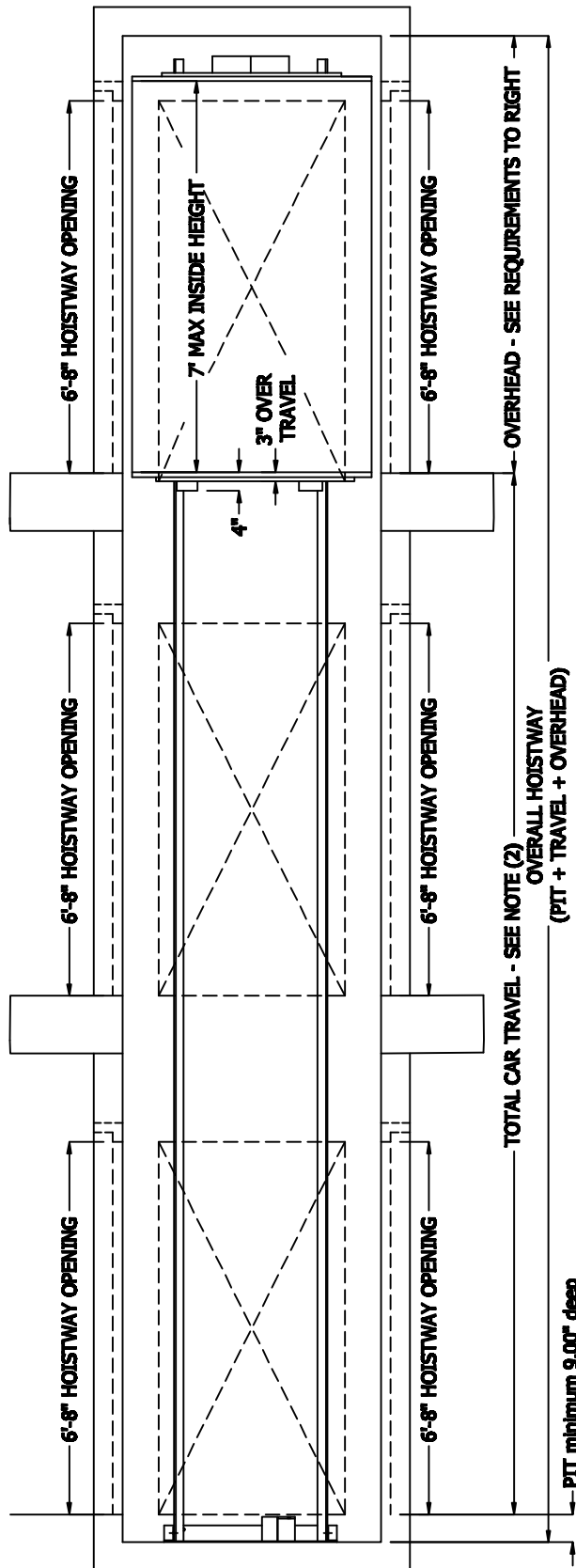

OVERHEAD REQUIREMENTS	
INTERIOR CAB HEIGHT	REQUIRED OVERHEAD
6'8"	92"
7'0"	96"
7'11"	107"

Overhead shall be measured from the finished flooring at the uppermost landing to the lowest obstruction in the top of the shaftway

## PIT REQUIREMENTS

The elevator shaftway shall have a pit at the lower most landing to accept the elevator and allow the cab to become flush with the lower most landing.

The pit shall be a minimum of 9.00" deep with a smooth level surface able to withstand the following loads.

- Impact load at pit                      4,750 Lbs
- Static load at pit                         2,900 Lbs

# MACHINE ROOM LAYOUT AND REQUIREMENTS

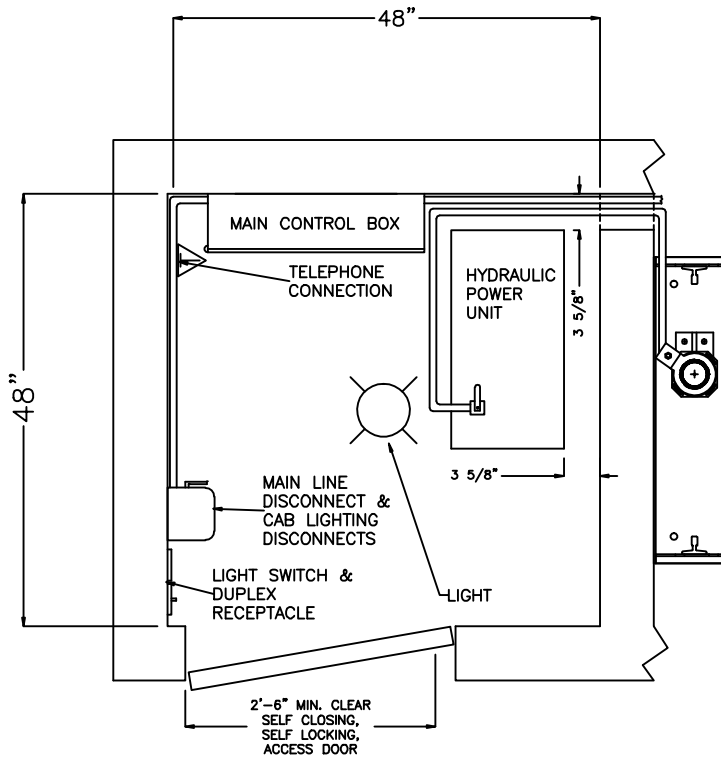

STANDARD MACHINE ROOM LAYOUT

MACHINE SPACE MUST MEET ALL LOCAL, STATE, AND NATIONAL CODES INCLUDING ALL NEC REQUIREMENTS

MAIN CONTROL PANEL  
20"W x 23.5"H x 6.5"D

HYDRAULIC PUMP UNIT  
24"W x 36"H x 16"D

CLEARANCE IN FRONT OF CONTROL PANEL AND DISCONNECTS PER NEC  
30"W x 36"D

## ELECTRICAL REQUIREMENTS

220V 30A DEDICATED LINE  
110V 15A DEDICATED LINE  
3 POLE MAIN LINE DISCONNECT  
CAR LIGHTING DISCONNECT  
TELEPHONE CONNECTION  
SELF CLOSING SELF LOCKING  
ACCESS DOOR.

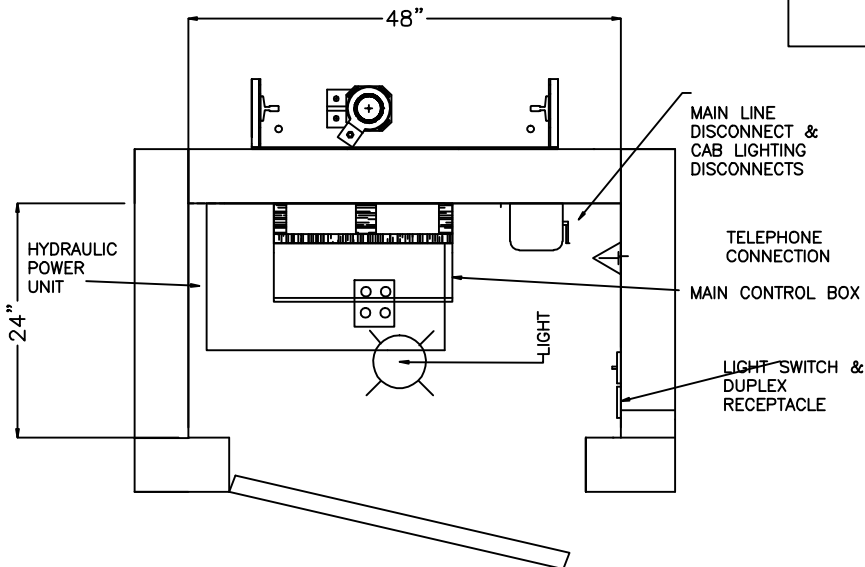

COMPACT MACHINE ROOM LAYOUT



# A.H.E. HOME ELEVATOR MANUFACTURING.

## 1:2 Roped Hydraulic Residential Elevator

## Technical Specifications

### PART 1 GENERAL

SEPTEMBER 2009

#### 1.01 SECTION INCLUDES

A. Residential elevator with 1:2 roped hydraulic lift system.

#### 1.02 WORK INCLUDED

A. Furnish all labor and materials, equipment and incidentals necessary to assemble and erect a residential elevator, complete with a remote power unit and all hoses, rails, brackets, connections and controls essential for proper operation.

#### 1.03 WORK BY OTHERS

A. Construct a hoistway of the size required by the manufacturer, complete with all demolition, additional framing, headers, and framing components necessary to prepare the building to receive the elevator.

1. Hoistway size: Dependant upon car size.
2. The hoistway shall be vertical to within 1/2" throughout the entire height.
3. Provide and fasten vertical structural members in hoistway, per manufacture's recommendation.
4. Pit requirements: Provide 9" deep pit Install reinforcement and concrete as necessary. Floor must sustain load specified in job drawings.

B. Construct a machine room:

1. Provide elevator electrical circuit: 208/230 volt AC/ 1 phase/ 60hz (30 amp)
2. Provide elevator lighting electrical circuit: 115 volt (15amp)

C. Provide system to maintain hoistway and machine room temperature between 50-90 degrees Fahrenheit.

#### 1.04 REFERENCES:

A. General: The applicable provisions of the following standards shall apply as if written here in their entirety.

B. American Society of Mechanical Engineers / American National Standards Institute (ASME/ANSI) publications: ASME/ANSI A17.1 "Safety Codes for Elevators and Escalators", Section 5.3.

C. National Fire Protection Association (NFPA) publications: NFPA 70 National Electrical Code

#### 1.05 SYSTEM DESCRIPTION:

- A. Travel: \_\_\_\_\_
- B. Stops: \_\_\_\_\_
- C. Load Capacity: 950 lb.
- D. Speed: 40 fpm

#### 1.06 QUALITY ASSURANCE

A. Qualifications:

Installer Qualifications: A company experienced in the assembly and erection of lifts and residential elevators of the type specified.

Manufacturer Qualifications: A company specializing in the manufacture of residential elevators.

B. Regulatory Requirements: The complete manufacture, fabrication and erecting of the elevator shall be in compliance with all Federal, State and local codes and ordinances. The installer shall verify requirements of the local authority having jurisdiction and shall comply with all local codes and ordinances.

#### 1.07 DELIVERY, HANDLING & STORAGE

A. All components shall be shipped to the site in substantial crates to protect from damage during shipping and handling. Upon arrival, inspect components and keep under cover until installed.

#### 1.08 WARRANTY

A. Unit shall have a two (2) year limited parts warranty.

#### 1.09 MAINTENANCE:

A. Maintenance of the private residential elevator shall consist of regular cleaning and inspection at intervals not longer than every 12 months.

B. Inspection: ASME A17.1 requires all private residential elevators to be inspected every 12 months.

### PART 2 PRODUCTS

#### 2.01 MANUFACTURER

A. A.H.E. Home Elevators

A. Substitutions: No substitution shall be considered unless written request for approval has been submitted and received by the architect at least ten (10) days prior to the bid date.

#### 2.02 COMPONENTS

A. Car:

1. Size: Dependant upon shaft size. Car dim not to exceed 15 FtSQ
2. Enclosure: Securely fastened to the car frame and platform. The car shall be constructed of minimum 3/4" wood walls. Floorboard shall be constructed of 3/4" AC plywood.
3. Gate: Accordion type equipped with a positively opened mechanical switch to indicate that the door is closed.  
Handrail: One located on the car wall.
4. Telephone: installed in recessed phone box
5. Control panel: Provide one momentary pressure illuminated button for each landing, emergency stop and alarm button all mounted in

a control panel having a stainless steel or brass cover.

6. Interior lighting: Provide overhead light fixtures that automatically turn on when the car is in operation and turn off by means of a timer circuit.

B. Hoistway door:

1. Size: 3'0" W x 6'8"H swing Type (by Others)
2. The general contractor or owner is to furnish and install hoistway doors, frames, hinges and passage sets at each landing. The type and installation of the doors and frames must comply with ASME A17.1, all local codes and manufacturer's layout drawings.
3. Locking Device: Door shall have a locking device, interlocked with the car operation, to interrupt electrical power when the door is not securely closed and a car is not at the landing. The door shall be locked when car is not in the landing zone.

C. Hydraulic power unit:

1. The pump, motor and valve shall be pre-wired, ready for connection to the controller in the field.
2. Up direction acceleration adjustment.
3. Two speed operation.
4. Adjustable pressure relief valves.
5. Manually operated down valve for emergency operation.
6. Pressure gauges and pressure gauge isolation valves.
7. Manual valve isolation between pump unit and jack.
8. Negative pressure switch provided.

D. Cylinder:

1. Construction: Steel pipe with cylinder head having an internal guide ring and self-adjusting packing.
2. Safety valve: Cylinder shall be equipped with a pipe rupture safety valve to prevent uncontrolled car descent.

E. Plunger:

1. Construction: Shall be a machined steel shaft equipped with a stop, electrically welded to bottom end, to prevent plunger from leaving shaft cylinder.

F. Suspension system: 1:2 system using (2) 3/8" – 7x19 aircraft cables integrated with rams header sheave mounted to the plunger.

G. Guide rail: Shall consist of two 8 lb. tee rails assembled and fastened. Provide brackets to hold rail assembly to walls. Rail shall be furnished with steel splice plates and hardware.

H. Car frame: Shall be equipped with non-metallic faced roller guide wheels.

I. Leveling device: Provide Position Sensor to maintain car within 1/4" of the landing.

J. Control systems: Non-Selective collective microprocessor

K. Motor: 2.5 HP, 208/230 VAC, single phase.

L. Wiring:

1. Provide flexible traveling cable for electrical lights and controls in car.
2. All other electrical wiring shall be insulated, flame retardant and moisture proof copper wiring, installed in flexible metal conduit.

M. Safety Devices:

1. Slack cable protection: Provide a linkage device that stops and sustains the car in the event of breakage or slackening of cables.
2. Terminal stopping device: Shall be provided at the top and bottom of the car travel.
3. Provide a platform toe guard at the car entrance.

N. Battery powered emergency operation system:

1. Powers a light in the car.

2. Powers an emergency alarm system.

3. Powers a system to allow car to descend to floor selected by passenger.

4. The batteries shall be a re-chargeable type complete with an automatic re-charging system.

O. "Self Diagnostic System" utilizing diagnostic codes displayed in hall and car acknowledgement lights to provide information in the event the elevator will not operate.

## PART 3 EXECUTION

### 3.01 INSTALLATION

A. Inspect the hoistway and determine if the hoistway meets the manufacturer's requirements for clearances and plumb.

B. All components shall be assembled and erected in strict compliance with manufacturer's printed instructions and applicable codes.

C. All wiring shall be in accordance with the wiring diagram furnished by the manufacturer and NEC.

### 3.02 FIELD QUALITY CONTROL

A. Static/Running Load Test: All load rating and safety factors shall meet or exceed those specified in ASME A17.1

### 3.03 ADJUSTING

A. Test the elevator to assure proper operation under all conditions of use. Make proper adjustments and review operating components for proper operation.

**For more details, call A.H.E Home Elevators 800-530-4040**





# AHE Home Elevators

127 Route 9 south  
Barnegat, NJ 08050  
800-530-4040

[www.ahehomeelevators.com](http://www.ahehomeelevators.com)

Your Authorized AHE Dealer: